

# P10 Seamless Switcher



## Specifications

## Change History

Document Version	Release Date	Description
V1.5.0	2024-10-20	<ul style="list-style-type: none"> <li>Added support for interlaced signal output.</li> <li>Updated the descriptions of input backup, BKG, and Stream Deck.</li> <li>Updated the dimensions of the flight case.</li> </ul>
V1.4.0	2024-06-05	Added dynamic frame rate calculation, Mac EDID compatibility, KeyFrame, and control of multiple P10 units.
V1.3.0	2024-02-02	Updated the front panel button descriptions.
V1.2.0	2024-01-05	<ul style="list-style-type: none"> <li>Added the multiple screen configuration, Cut &amp; Fill, edge blending, LCD bezel compensation, DSK and device backup.</li> <li>Updated the layer resource description.</li> <li>Updated the button and connector descriptions.</li> <li>Updated the application topology.</li> </ul>
V1.1.0	2023-09-30	<ul style="list-style-type: none"> <li>Added a description for Stream Deck.</li> <li>Updated the application topology.</li> </ul>
V1.0.1	2023-06-30	<ul style="list-style-type: none"> <li>Added the maximum power consumption and noise level.</li> <li>Deleted the USB cable.</li> </ul>

## Introduction

PIXELHUE's P10 is a new 4K seamless switcher fully featured in a compact form factor. This seamless switcher is designed with a wide variety of 4K connectors, featuring video processing, image mosaic, transition effects, multi-screen display, and much more. The P10 is suitable for small/medium-sized live events such as conferences, exhibitions and shows, and many fixed installations.

The P10 has powerful signal receiving and processing capabilities. It supports up to 6x 4K video inputs. In PGM only mode, the output resolution per P10 is up to 8Kx2K@60Hz. In switcher mode, a single P10 supports one 4Kx2K@60Hz output. It supports 2x AUX outputs and 1x Multiviewer output. Additionally, 10G optical fiber ports are provided, allowing the P10 to transmit signals over a long distance without fiber converters. High-performance image deinterlacing is also supported.

The P10 supports two working modes: switcher mode and PGM only mode and features up to 6 layers, advanced DSK capability, transition effects such as fade in and fade out, and custom test patterns. High-resolution images can be captured from live inputs and outputs. Up to 128 presets can be saved for easy recall. Visualized live view of input and output connector statuses are also supported.

Besides, the P10 comes with a 5-inch graphical LCD screen on the front panel, allowing for more efficient and intuitive control. Users can control the P10 with the front panel LCD, event controller U5/U5 Pro, event management software PixelFlow, or third-party control system Stream Deck, making control more flexible and easier.

## Certifications

FCC, IC, CE, KC, CB

**If the product does not have the relevant certifications required by the countries or regions where it is to be sold, please contact PIXELHUE to confirm or address the problem. Otherwise, the customer shall be responsible for the legal risks caused or PIXELHUE has the right to claim compensation.**

## Features

### Input and Output

- 6x 4K video inputs
  - 2x 12G-SDI (with loop output)
  - 4x DP 1.2/HDMI 2.0 (Only one can be selected at the same time)
- 12bit/10bit/8bit video sources supported
- Genlock synchronization signal input (with loop output)
- Automatic HDCP decryption for inputs and HDCP encryption for outputs
- Deinterlacing of SDI video sources
- Output capacity switching
  - 2x HDMI 2.0 and 6x HDMI 1.3
    - 4K: In switcher mode, one connector works as primary and the other works as backup for 4K output. In PGM only mode, two connectors work as primary for 4K output.
    - SL: In switcher mode, four connectors work as primary and the other four work as backup for 2K output. In PGM only mode, eight connectors work as primary for 2K output.
- 2x AUX outputs
  - 2x HDMI 1.3 connectors for connecting to auxiliary devices such as teleprompters
- 1x MVR output
  - 1x HDMI 1.3 connector for connecting to a Multiviewer screen to monitor all input sources, PVW, PGM and display the resolution, frame rate and more
- 10G optical fiber outputs
  - 4x OPT ports for copying the output images of HDMI connectors
- 2x audio inputs and 2x audio outputs (to be implemented in future updates)
  - 3.5 mm audio jacks

### Functionality

- Two working modes: Switcher mode and PGM only mode
- High-precision output synchronization

- 
- Compatible with EDID on Mac
  - Multi-screen configuration
    - Each connector can create a screen. All the screens have the same resolution.
    - Multiple output connectors supports splicing for uneven screen division, with each connector driving a section of the screen with varying resolutions.
    - Virtual pixel configuration is supported, simplifying calculations between on-site screen size and P10-loaded screen pixels.
  - 6x Layers
    - Up to 2x MAIN DL layers (or 1x MAIN 4K layer) and 4x PIP DL layers (or 2x PIP 4K layers)
    - Each layer supports cross-connector output.
    - The Z-order of MAIN layers and the Z-order of PIP layers can be adjusted.
    - Input source capturing is supported.
    - MAIN layers support border and shadow. All layers support mask and flip.
    - KeyFrame is supported. (Only layer position and size can be adjusted for now. Additional functionalities will be implemented in future updates.)
    - Layer preset: Save layer properties and apply them to other layers for quick configuration.
  - Cut & Fill

Use the original layer as a Fill layer and overlap it with the Cut layer to display the visible image of the Cut layer, allowing users to define output shapes and effects more flexibly.
  - Edge blending

Blend the overlapping edges of the images projected by multiple projectors to ensure uniform brightness across the entire display.
  - LCD bezel compensation

Eliminate the visual disruption caused by seams in spliced LCD displays, resulting in a more unified and seamless display.
  - Advanced DSK capability

Smart key, luma key, and chroma key are supported.
  - BKG settings
    - BKG can be loaded from the control computer or event controller.
    - Images can be used as BKG.
    - Images captured from input sources and PGM can be used as BKG.
    - BKG can be turned on or off.
    - BKG can be changed and deleted.
    - The aspect ratio, position and size of BKG can be adjusted.
  - Preset recall

Up to 128 presets can be saved for easy recall.
  - Custom test patterns

Set a test pattern for screen test and problem identification.
  - Output connector replacement

In case of screen mosaic, when a physical connector fails or is damaged, the output connector can be replaced through the software.
-

- Output connector copying

Each output connector has a corresponding backup connector which copies the data of the primary connector.

- Input source hot backup

Specify primary and backup input sources. Once the primary input source disappears, it will be switched to the backup source automatically.

- Device backup

With device backup enabled, when a layer's input source is missing or has no signal, all output connectors for the screen immediately stop signal output, initiating a switch to the backup channel through coordination with the sending and receiving cards.

- Connector status monitoring

Visualized live monitoring of input and output connector statuses

- Multiple control options

- Front panel buttons and LCD
- Event controller U5/U5 Pro
- Event management software PixelFlow

Multiple switchers can be controlled simultaneously by PixelFlow.

- Third-party control system Stream Deck (Companion integrated into the P10)

## Video Source

Input	Bit Depth	Sampling Format	Supported Resolutions	Supported Bandwidth
DP 1.2	8bit	RGB 4:4:4	4096×2160@60Hz	18Gbps
		YCbCr 4:4:4	8192×1080@60Hz	
		YCbCr 4:2:2		
	10bit	RGB 4:4:4	4096×2160@30Hz	
		YCbCr 4:4:4	4096×1080@60Hz	
		YCbCr 4:2:2	4096×2160@60Hz	
	12bit	RGB 4:4:4	4096×2160@30Hz	
		YCbCr 4:4:4	4096×1080@60Hz	
		YCbCr 4:2:2	4096×2160@60Hz	
HDMI 2.0	8bit	RGB 4:4:4	4096×2160@60Hz	18Gbps
		YCbCr 4:4:4	8192×1080@60Hz	
		YCbCr 4:2:2		
	10bit	RGB 4:4:4	4096×2160@30Hz	
		YCbCr 4:4:4	4096×1080@60Hz	
		YCbCr 4:2:2	4096×2160@60Hz	
	12bit	RGB 4:4:4	4096×2160@30Hz	
		YCbCr 4:4:4	4096×1080@60Hz	

Input	Bit Depth	Sampling Format	Supported Resolutions	Supported Bandwidth
		YCbCr 4:2:2	4096×2160@60Hz	
12G-SDI	10bit	YCbCr 4:2:2	4096×2160@60Hz	11.88Gbps

## Appearance

### Front Panel

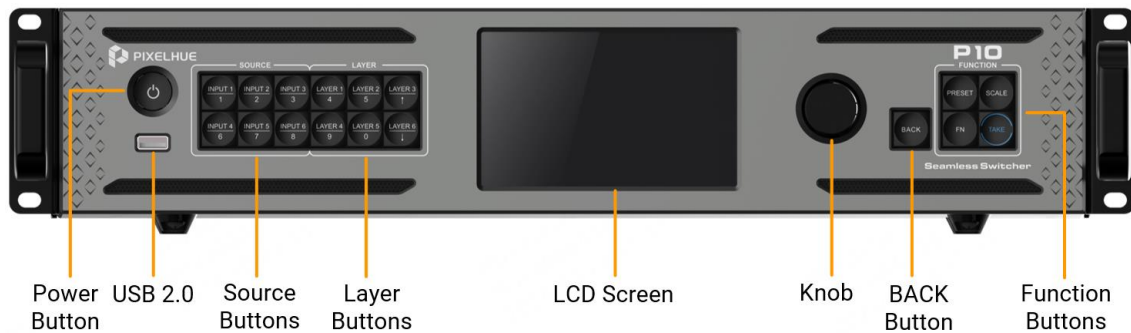

Name	Description
Power Button	<p>Press the button to turn on/off the device. To turn off the device, press the button and select <b>OK</b> from the dialog box displayed on the LCD screen to confirm your operation.</p> <ul style="list-style-type: none"> <li>• Breathing dim white: The power supply is connected.</li> <li>• Bright white: The device is turned on.</li> </ul>
USB 2.0	<p>A Type-A USB 2.0 port is provided for updating device firmware, import and export project files, EDID files, BKG files, LOGO files and logs via USB drive.</p>
Source Buttons	<p>Press a button to access the input settings menu or select the source. These buttons can also be used to enter numbers.</p> <ul style="list-style-type: none"> <li>• Dim white: No signal and not in use</li> <li>• Breathing blue: Signal accessed and not in use</li> <li>• Blue: In use</li> </ul>
Layer Buttons	<p>Press a button to open the layer and access the layer menu. Press and hold the button to close the layer. These buttons can also be used to enter numbers and turn pages.</p> <ul style="list-style-type: none"> <li>- Dim white: The layer is closed.</li> <li>- Bright blue: The layer is open.</li> <li>- Blinking blue: The layer is in edit mode.</li> </ul>
LCD Screen	<p>A 5-inch graphical LCD screen is designed for displaying all the menus, submenus and messages.</p>
Knob	<ul style="list-style-type: none"> <li>• Rotate the knob to scroll up or down through the menus.</li> <li>• Press the knob to select menu items.</li> <li>• Press and hold the knob and <b>BACK</b> button simultaneously for 3s or longer to lock or unlock the front panel buttons.</li> </ul>
BACK	<ul style="list-style-type: none"> <li>• Press the <b>BACK</b> button to exit a menu without making changes, to cancel an operation, or to return to the home screen. Each press takes you back up the menu tree one level.</li> </ul>

Name	Description
	<ul style="list-style-type: none"> <li>Press and hold the knob and <b>BACK</b> button simultaneously for 3s or longer to lock or unlock the front panel buttons.</li> </ul>
Function Buttons	<p>Shortcut buttons for the currently selected screen</p> <ul style="list-style-type: none"> <li><b>PRESET:</b> Press the button to access the preset settings menu.                             <ul style="list-style-type: none"> <li>Dim white: The preset settings menu is not displayed.</li> <li>Blinking blue: The preset settings menu is displayed.</li> </ul> </li> <li><b>SCALE:</b> Press the button to enable the full screen scaling of the layer at the back of the Z-order.                             <ul style="list-style-type: none"> <li>Blinking blue: Full screen scaling is enabled successfully.</li> </ul> </li> <li><b>FN:</b> This is a custom shortcut button and users can assign a function to it.                             <p>When Freeze, FTB (Fade to Black) or Genlock synchronization is assigned, press the button to enable or disable the assigned function.</p> <ul style="list-style-type: none"> <li>Dim white: The function is disabled.</li> <li>Blue: The function is enabled.</li> </ul> <p>When Capture is assigned, press the button to access the <b>Capture</b> menu.</p> <ul style="list-style-type: none"> <li>Dim white: The <b>Capture</b> menu is displayed.</li> <li>Blinking blue: Capturing...</li> </ul> </li> <li><b>TAKE:</b> Press the button to switch content from PVW to PGM with a specified transition effect.                             <ul style="list-style-type: none"> <li>Dim white: Content is not switched.</li> <li>Blinking blue: Content is being switched.</li> </ul> </li> </ul>

## Rear Panel

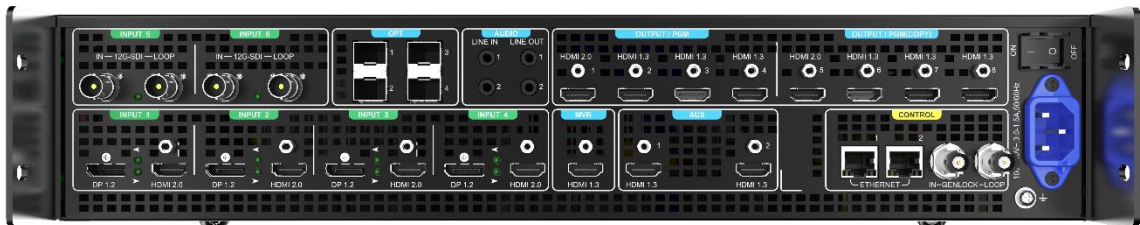

Name	Qty	Description	
<b>INPUT 1 to 4</b>			
Each includes a DP 1.2/HDMI 2.0. When two connectors have signals, only one can be used as the input source at the same time.			
DP 1.2	4	Resolution	Max resolution: 4096×2160@60Hz/8192×1080@60Hz Min resolution: 800×600@60Hz
		Max width/height	Max width: 8192 pixels (8192×1080@60Hz) Max height: 8192 pixels (1080×8192@60Hz)
		Frame rate	Up to 120Hz
		EDID management	Support for standard resolutions up to 8192×1080@60Hz Support for custom resolutions
		HDCP	HDCP 1.3 compliant

Name	Qty	Description	
		Interlaced signal	Not supported
HDMI 2.0	4	Resolution	Max resolution: 4096×2160@60Hz/8192×1080@60Hz Min resolution: 800×600@60Hz
		Max width/height	Max width: 8192 pixels (8192×1080@60Hz) Max height: 8192 pixels (1080×8192@60Hz)
		Frame rate	Up to 120Hz
		EDID management	Support for standard resolutions up to 3840×2160@60Hz Support for custom resolutions
		HDCP	HDCP 2.2 compliant and backward compatible
		Interlaced signal	Not supported
<b>INPUT 5 to 6</b>			
12G-SDI IN & LOOP	2 groups	Standard	Support for ST-2082 (12G), ST-2081 (6G), ST-424 (3G), ST-292 (HD), and ST-259 (SD) video inputs
		Resolution	Up to 4096×2160@60Hz
		Frame rate	Up to 60Hz
		EDID management	Not supported
		Interlaced signal	Supported
<b>OPT</b>			
1 to 4	2 groups	Optical fiber output ports for copying HDMI output images	
		<b>4K</b> <ul style="list-style-type: none"> <li>Switcher mode                             <ul style="list-style-type: none"> <li>OPT 1 copies the left half of the output image of HDMI 1.</li> <li>OPT 2 copies the right half of the output image of HDMI 1.</li> <li>OPT 3 copies the left half of the output image of HDMI 1.</li> <li>OPT 4 copies the right half of the output image of HDMI 1.</li> </ul> </li> <li>PGM only mode                             <ul style="list-style-type: none"> <li>OPT 1 copies the left half of the output image of HDMI 1.</li> <li>OPT 2 copies the right half of the output image of HDMI 1.</li> <li>OPT 3 copies the left half of the output image of HDMI 5.</li> <li>OPT 4 copies the right half of the output image of HDMI 5.</li> </ul> </li> </ul>	
		<b>SL</b> <ul style="list-style-type: none"> <li>Switcher mode                             <ul style="list-style-type: none"> <li>OPT 1 copies HDMI 1 and HDMI 2.</li> <li>OPT 2 copies HDMI 3 and HDMI 4.</li> <li>OPT 3 copies HDMI 1 and HDMI 2.</li> <li>OPT 4 copies HDMI 3 and HDMI 4.</li> </ul> </li> <li>PGM only modes                             <ul style="list-style-type: none"> <li>OPT 1 copies HDMI 1 and HDMI 2.</li> <li>OPT 2 copies HDMI 3 and HDMI 4.</li> </ul> </li> </ul>	

Name	Qty	Description	
		OPT 3 copies HDMI 5 and HDMI 6. OPT 4 copies HDMI 7 and HDMI 8.	
<b>AUDIO</b>			
LINE IN	2	3.5 mm dual-channel audio input jacks with a default sampling rate of 48kHz (to be implemented in future updates)	
LINE OUT	2	3.5 mm dual-channel audio output jacks with a default sampling rate of 48kHz (to be implemented in future updates)	
<b>OUTPUT/PGM and OUTPUT/PGM (COPY)</b>			
<ul style="list-style-type: none"> <li>• 4K <ul style="list-style-type: none"> <li>– In switcher mode, connector 1 works as primary for 4K output and connector 5 copies connector 1.</li> <li>– In PGM only mode, connectors 1 and 5 can work as primary and have the same resolution.</li> </ul> </li> <li>• DL <ul style="list-style-type: none"> <li>– In switcher mode, connectors 1, 2, 3 and 4 work as primary and connectors 5, 6, 7 and 8 copy connectors 1, 2, 3 and 4, respectively. Connectors 1, 2, 3 and 4 have the same resolution.</li> <li>– In PGM only mode, eight connectors work as primary. All the connectors have the same resolution.</li> </ul> </li> </ul>			
HDMI 2.0	2	Resolution	Max resolution: 4096×2160@60Hz/8192×1080@60Hz Min resolution: 800×600@60Hz
		Max width/height	Max width: 8192 pixels (8192×1080@60Hz) Max height: 8192 pixels (1080×8192@60Hz)
		Frame rate	Up to 120Hz
		EDID management	Support for standard resolutions up to 3840×2160@60Hz Support for custom resolutions
		HDCP	HDCP 2.2 compliant and backward compatible
		Interlaced signal	Supported
HDMI 1.3	6	Resolution	Max resolution: 1920×1080@60Hz/2048×1080@60Hz Min resolution: 800×600@60Hz
		Max width/height	Max width: 2048 pixels (2048×1080@60Hz) Max height: 2048 pixels (1080×2048@60Hz)
		Frame rate	Up to 120Hz
		EDID management	Support for standard resolutions up to 2048×1152@60Hz Support for custom resolutions
		HDCP	HDCP 2.2 compliant and backward compatible
		Interlaced signal	Supported
<b>MVR</b>			
HDMI 1.3	1	Multiviewer output connector with a default resolution of 1920×1080@60Hz. The frame rate can be changed.	
<b>AUX</b>			
HDMI 1.3	2	AUX output connectors with a default resolution of 1920×1080@60Hz and support for interlaced video signal output. Auxiliary devices such as teleprompters can be connected.	

Name	Qty	Description
<b>CONTROL</b>		
ETHERNET	2	<ul style="list-style-type: none"> <li>• Used for control and input view.</li> <li>• One works as primary and the other as backup.</li> <li>• They have the same function and share the same IP address.</li> </ul>
GENLOCK	1 group	Genlock synchronization signal connectors <ul style="list-style-type: none"> <li>• IN: Synchronization signal input</li> <li>• LOOP: Synchronization signal loop output</li> </ul>
<b>Power</b>		
100-240V~, 3.0-1.5A, 50/60Hz	1	Power connector and rocker switch <ul style="list-style-type: none"> <li>• ON: Power on</li> <li>• OFF: Power off</li> </ul>

## Dimensions

### P10

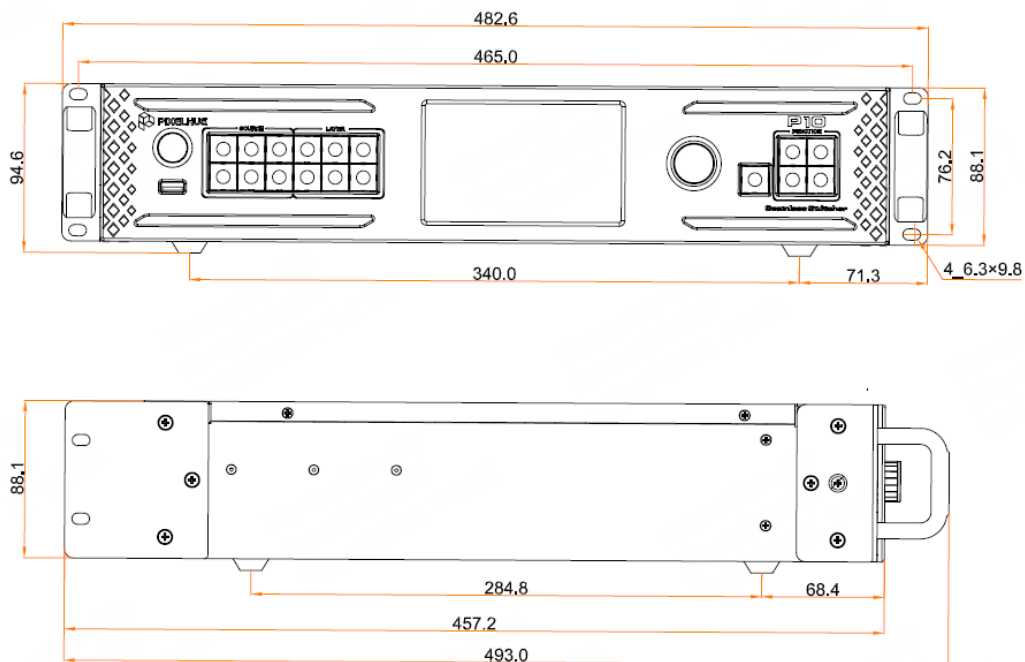

Tolerance: ±5 Unit: mm

## Flight Case

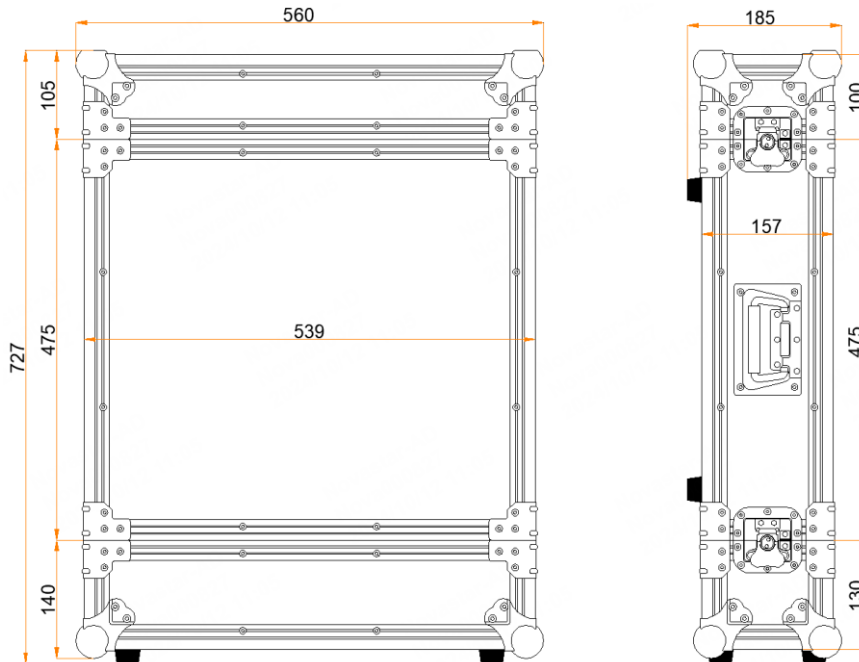

Tolerance:  $\pm 5$  Unit: mm

### Notes

If you require detailed dimensions and drawings of the flight case, please contact PIXELHUE customer service team.

## Applications

### Switcher mode

When the output capacity is 4K, one HDMI 2.0 connector works as primary and the other works as backup. When the output capacity is SL, four output connectors work as primary and the other four work as backup. SL output capacity is used as an example for illustration of projection. The P10 can work with the U5 or U5 Pro event controller. The following takes the U5 as an example for illustration.

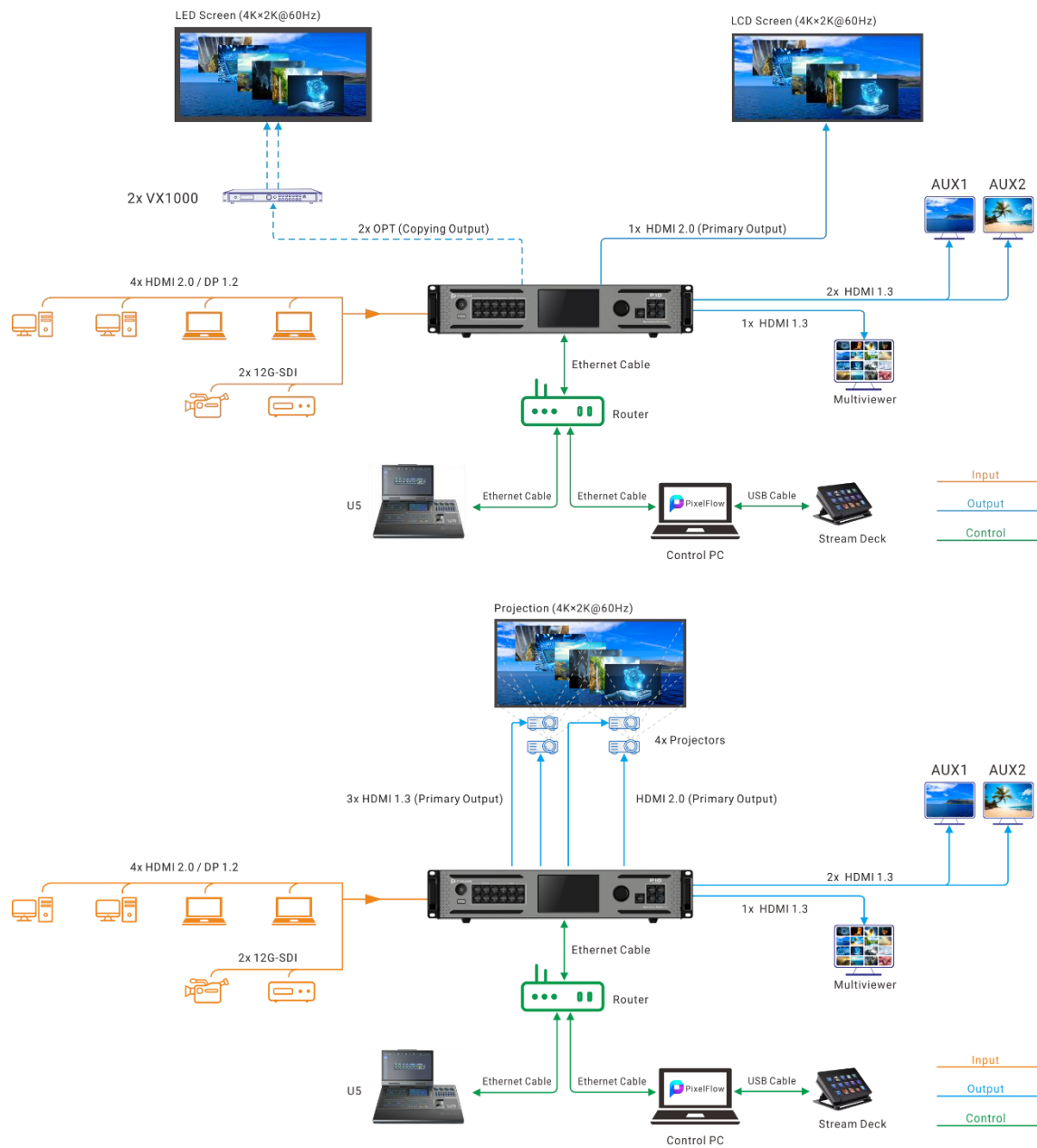

## PGM Only Mode

When the output capacity is 4K, two HDMI 2.0 connectors are used for 4K output. When the output capacity is SL, eight connectors are used for 2K output. 4K output is used as an example for illustration of projection. The P10 can work with the U5 or U5 Pro event controller. The following takes the U5 as an example for illustration.

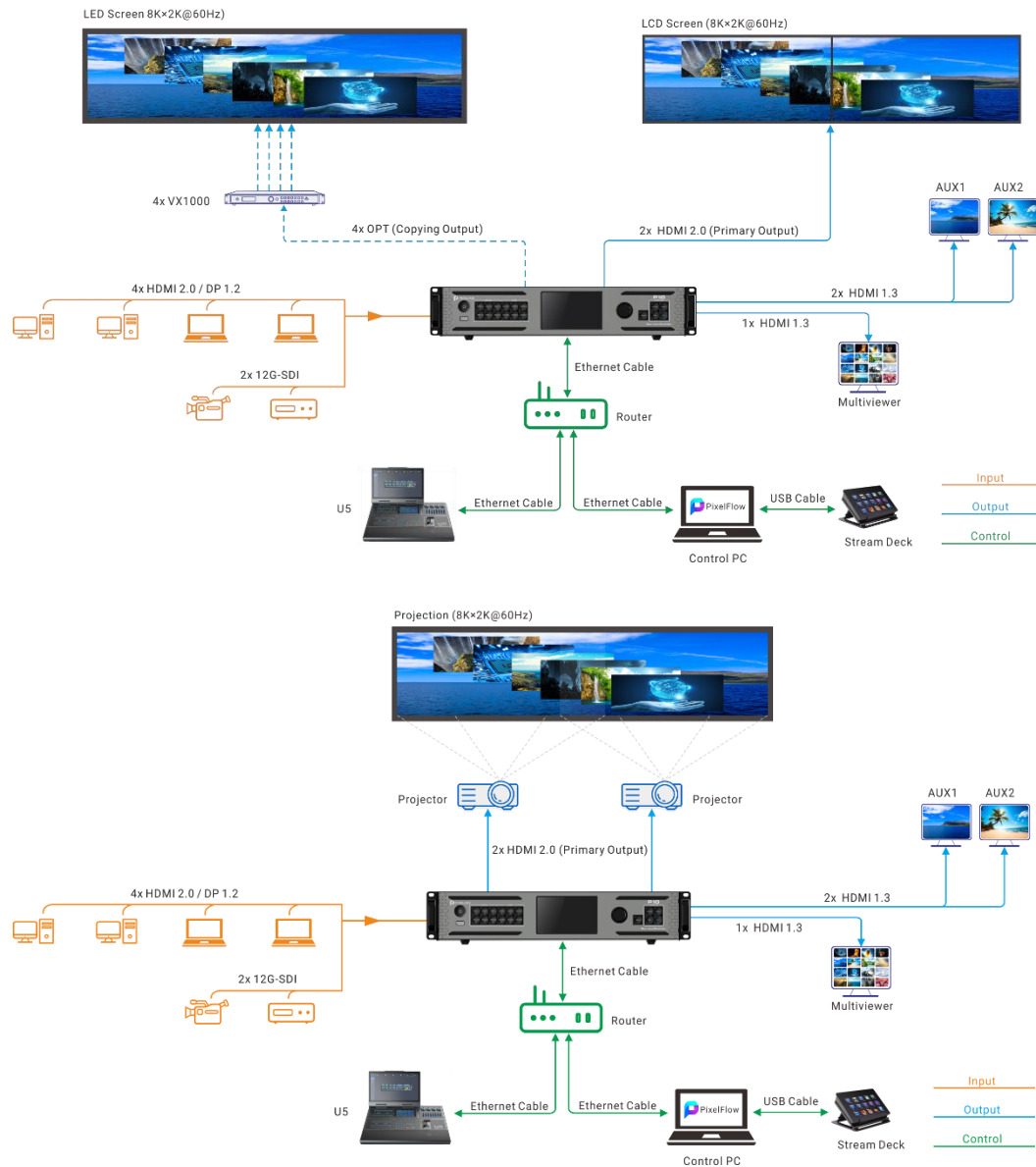

## Specifications

Electrical Specifications	Power supply	100-240V~, 3.0-1.5A, 50/60Hz
	Max power consumption	82 W
Operating Environment	Temperature	0°C to 50°C (32°F to 122°F)
	Humidity	0% RH to 80% RH, non-condensing
Storage Environment	Temperature	-20°C to +60°C (-4°F to 140°F)
	Humidity	0% RH to 95% RH, non-condensing
Physical Specifications	Dimensions	482.6 mm × 493.0 mm × 94.6 mm
	Net weight	7.9 kg / 17.4 lbs
	Gross weight	10.2 kg / 22.5 lbs

	(packed with paper box)	Note: It is the total weight of the product, accessories, and packing materials packed with a paper box.
	Gross weight (packed with flight case)	20.6 kg / 45.4 lbs Note: It is the total weight of the product, accessories, and packing materials packed with a flight case.
Packing Information	Paper box	660 mm × 570 mm × 210 mm
	Flight case	560 mm × 185 mm × 727 mm
	Accessories	<ul style="list-style-type: none"> <li>• 1x Power cable</li> <li>• 1x Ethernet cable</li> <li>• 1x HDMI cable</li> <li>• 1x DP cable</li> <li>• 1x Customer Letter</li> <li>• 1x Quick Start Guide</li> <li>• 1x Safety Manual</li> <li>• 1x Certificate of Approval</li> </ul>
Noise (Typical at 25°C/77°F)	41.9 dB (A)	

The amount of power consumption may vary depending on various factors such as product settings, usage, and environment.

## Notes and Cautions

### Notes for Installation

When the product needs to be installed on the rack, 4 screws at least M5\*12 should be used to fix it. The rack for installation shall bear at least 32.0kg weight.

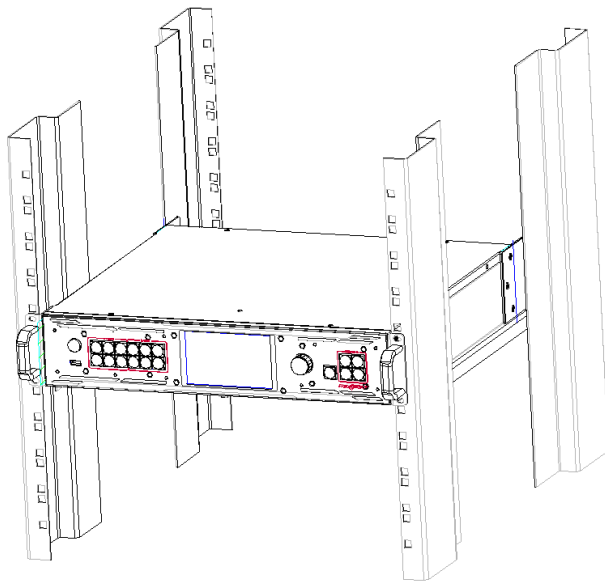

- **Elevated Operating Ambient** - If installed in a closed or multi-unit rack assembly, the operating ambient temperature of the rack environment may be greater than room ambient. Therefore, consideration should be given to installing the equipment in an environment compatible with the maximum ambient temperature (T<sub>ma</sub>) specified by the manufacturer.
- **Reduced Air Flow** – Installation of the equipment in a rack should be such that the amount of air flow required for safe operation of the equipment is not compromised.
- **Mechanical Loading** – Mounting of the equipment in the rack should be such that a hazardous condition is not achieved due to uneven mechanical loading.
- **Circuit Overloading** – Consideration should be given to the connection of the equipment to the supply circuit and the effect that overloading of the circuits might have on overcurrent protection and supply wiring. Appropriate consideration of equipment nameplate ratings should be used when addressing this concern.
- **Reliable Earthing** – Reliable earthing of rack-mounted equipment should be maintained. Particular attention should be given to supply connections other than direct connections to the branch circuit (e.g. use of power strips).

## FCC Caution

Any changes or modifications not expressly approved by the party responsible for compliance could void the user's authority to operate the equipment.

This device complies with part 15 of the FCC Rules. Operation is subject to the following two conditions: (1) This device may not cause harmful interference, and (2) this device must accept any interference received, including interference that may cause undesired operation.

Note: This equipment has been tested and found to comply with the limits for a Class A digital device, pursuant to part 15 of the FCC Rules. These limits are designed to provide reasonable protection against harmful interference when the equipment is operated in a commercial environment. This equipment generates, uses, and can radiate radio frequency energy and, if not installed and used in accordance with the instruction manual, may cause harmful interference to radio communications. Operation of this equipment in a residential area is likely to cause harmful interference in which case the user will be required to correct the interference at his own expense.

## Others

This is Class A product. In a domestic environment, this product may cause radio interference in which case the user may be required to take adequate measures.

This product can only be placed horizontally. Do not mount vertically or upside-down.

**TECNOGROUP**  
LED TECHNOLOGY EXPERTS

Tel: +56 9 5449 1032  
Email: [contacto@tecnogroup.cl](mailto:contacto@tecnogroup.cl)

**Casa Matriz**  
Padre Hurtado Central 580  
Las Condes, Santiago de Chile

[www.tecnogroup.cl](http://www.tecnogroup.cl)

Tel: 833 533 4255  
Email: [info@tecnogroup.us](mailto:info@tecnogroup.us)

**Showroom Miami**  
759 NW. 24th ST.  
Miami, FL 33127

[www.tecnogroup.us](http://www.tecnogroup.us)