

MX40 Pro

LED Display Controller



Specifications

Change History

Document Version	Release Date	Description
V1.4.1	2024-08-13	Added certification information for EAC
V1.4.0	2024-06-13	<ul style="list-style-type: none"> • Added certification information for KC. • Added the function of synchronous output from optical and Ethernet ports. • Added the function of setting optical port output mode. Users may choose between 20-port mode and 40-port mode. • Supports importing 3D LUT files with an accuracy of 33x33x33 / 65x65x65. • Added information for supported receiving card models.
V1.2.0	2023-01-03	<ul style="list-style-type: none"> • Added the function of changing the temperature scale. • Added a layer scaling mode: fill screen. • Support the SNMP and Art-Net protocols.
V1.1.0	2022-11-07	<ul style="list-style-type: none"> • Updated the description of the USB port on the front panel. • Optimized the description of Ethernet port load capacity.

Introduction

The MX40 Pro is a flagship all-in-one LED display controller with 20 Ethernet ports in the brand-new control system COEX series of Xi'an NovaStar Tech Co., Ltd. (hereinafter referred to as NovaStar). This controller integrates video processing and video control into one box and offers rich video input connectors (HDMI 2.0, DP 1.2 and 12G-SDI), 20x Ethernet output ports and 4x 10G optical ports (supports synchronous output). It can also work with the brand-new software VMP (Vision Management Platform) to provide a better operation and control experience.

Certifications

CCC, CE, FCC, IC, UL, CB, KC, EAC

If the product does not have the relevant certifications required by the countries or regions where it is to be sold, please contact NovaStar to confirm or address the problem. Otherwise, the customer shall be responsible for the legal risks caused or NovaStar has the right to claim compensation.

Features

Inputs and Outputs

- 3 types of inputs
 - 3x HDMI 2.0 (with loop through)
 - 1x DP 1.2
 - 1x 12G-SDI (with loop through)
- 12-bit, 10-bit and 8-bit video inputs
- 3 types of outputs
 - 20x Gigabit Ethernet ports, load capacity up to 9 million pixels
 - 4x 10G optical ports, supporting setting of output mode. Users may choose between 20-port mode and 40-port mode.
 - 1x SPDIF digital audio port
- 3 types of controls
 - 1x Genlock signal input (with loop through)
 - 2x Ethernet control ports
 - 1x Auxiliary port

Advanced Features

- 4 independent layers
Support up to 4x 4K layers and layer priority adjustment in Z order.
- Image scaling
Support 4 image scaling modes: custom, pixel to pixel, snap to canvas, and fill screen.
- Color Replacement
Support free replacement of any color on the image without affecting the performance of other colors. Replacement of highly saturated colors is recommended for better effect.
- 14Ch Color Correction
Support precise adjustment to hue, saturation and brightness of black, white and the 12 derived standard colors of the red, green and blue primary colors.
- Curves
Support adjustment to the image RGBW mapping curves.
- 3D LUT
Use the 3D LUT file (.cube) with an accuracy of 17×17×17 / 33×33×33 / 65×65×65 to adjust the colors of the video source.
- Dynamic Booster
Real-time analysis and dynamic adjustment are made to each frame to significantly improve the display contrast and image details for better visual experience, and effectively control and lower the display power consumption, extending the service life of the LED screen.
- Full Grayscale Calibration
Work with NovaStar's high-precision calibration system and C3200 scientific grade camera to generate unique calibration coefficients for each grayscale, ensuring uniformity of each grayscale and dramatically improving the image quality.
- 3D
Work with 3D emitter and 3D glasses to bring a fascinating and immersive 3D viewing experience.
- HDR
 - Support HDR10 and comply with the SMPTE ST 2084 and SMPTE ST 2086 standards.
 - Support HLG.
- Latency
 - Support low latency and the controller load capacity is not reduced. The latency at the controller is 0 frame (less than 1 ms) in Send-Only Controller working mode and 1 frame in All-In-One Controller working mode.
 - Support additional latency. Zero to two frames of latency can be added at the controller.
- Preset
For optimal display in various scenarios, users can adjust display parameters such as layers, brightness, color temperature, and gamma ahead of time and save them as presets. Users can save up to 128 customizable presets which can be easily applied or switched with just one click.
- No rectangle restriction
No rectangle restriction for irregular screens. When calculating resolutions, blank pixels do not count towards the total capacity. The used load capacity of Ethernet ports is the sum of the pixels of all cabinets.
- Frame Rate Adaptive
Automatically adapt to video inputs with different frame rates ranging from 23.98 Hz to 240 Hz, and support the automatic calculation of optimal screen parameters based on the input source's frame rate. This ensures that the brightness deviation of the screen remains within 5% across different frame rates. It also supports precise frame rate adjustment in 0.01 Hz increments.
- Two working modes
Support the All-In-One Controller and Send-Only Controller working modes.
 - In the Send-Only Controller mode, the latency can be reduced by one frame.
 - In the All-In-One Controller mode, the layer and scaling functions are available.
- Shutter Fit
Automatically adjusts the driver IC parameters according to the camera shutter angle to fix problems of black lines, grayscale addition, and grayscale loss during camera shooting in xR scenarios.
- Frame Multiplication
 - Frame interpolation: Outputs images that are captured from multiple shooting angles with different backgrounds at the same time. Solid green backgrounds can also be inserted to allow for easy post-production adjustments.
 - Frequency multiplication: Supports high frame rates of up to 240 Hz. This feature is to accommodate multi-angle camera shooting to improve the screen performance under the camera.

Device Controls

- VMP software control
The device can be connected to the VMP software to provide easy and convenient operations and smart device management.
- SNMP and Art-Net protocols supported
- Cascading control via Ethernet
The Gigabit Ethernet control ports support TCP/IP protocol and star topology. No switch or router is needed to deploy multiple devices on the same LAN via device cascading as the network switching function is already built in.
- Display system monitoring
Hardware monitoring capabilities that encompass fan speed, module temperatures, voltage levels, and operational status. It automatically detects and reports any device faults or alarm information, ensuring real-time monitoring of the LED screen's operational status

Table 1-1 Function Limitations

Function	Limitation
Frame Rate Adaptive	To use this function, it is required to pair with the A10s Pro receiving card and specific driver ICs (for detailed IC models, please see the product specifications on the NovaStar website at https://www.novastar.tech/). Additionally, you must use the Cabinet Tool provided by NovaStar to adjust the driver IC parameters for different frame rates, which will generate the required NCP file.
Dynamic Booster	It is required to work with the A10s Pro receiving card and users need to use a CA410-VP427, CA410-P427, or CA410-P427H colorimeter to perform the gamut and brightness correction.
Full Grayscale Calibration	It is required to work with the A10s Pro receiving card and users need to use a C3200 camera to perform full-grayscale calibration.
3D	3D cannot be enabled simultaneously with Low Latency and Frame Multiplication. To use the 3D function, specified 3D glasses are needed. For details, please contact NovaStar technical support.
Low Latency	Low Latency cannot be enabled simultaneously with Genlock, 3D, and Frame Multiplication. Moreover, it is recommended to ensure all Ethernet ports load the cabinets vertically and share the same Y coordinate (all set to 0) when Low Latency is enabled.
HDR	The HDR function supports automatic parsing and manual setting. The properties of 12G-SDI sources, DP1.2 sources and non-standard HDR sources can be manually set to HDR properties. Using the HDR function reduces the MX40 Pro load capacity by less than half if the MX40 Pro works with the A10s Pro receiving card. For details, see the Ethernet Port Load Capacity section.

Table 1-2 Supported Receiving Card Models

Receiving Card Model	Supported
A5s Plus	Yes
A7s Plus	Yes
A8s and its series	Yes
A8s-N	Yes
A8s Pro and its series	Yes
A10s Pro and its series	Yes

Appearance

Front Panel

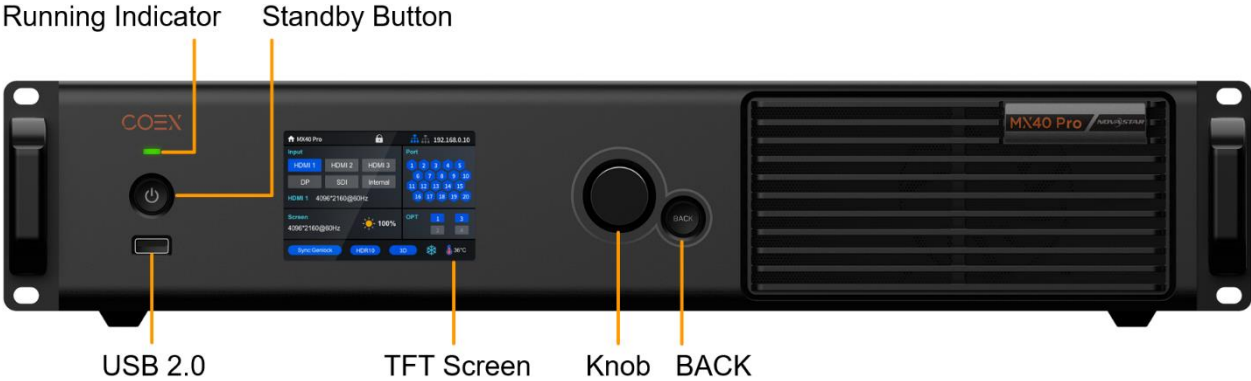

Name	Description
Running Indicator	<ul style="list-style-type: none"> • Solid red: Standby • Solid blue: The device is being started. • Solid green: The device is running normally. • Flashing red: The device is running abnormally.
Standby Button	<ul style="list-style-type: none"> • Press the button to power on or power off the device. • Hold down the button for 5s or longer to restart the device.
USB 2.0	<ul style="list-style-type: none"> • Connect to a USB drive only to export the device diagnostic result. • Only the NTFS and FAT32 file systems are supported. Others are not supported.
TFT Screen	A 3.5-inch screen to display the device status, menus, submenus and messages for parameter settings
Knob	<ul style="list-style-type: none"> • On the home screen, press the knob to enter the main menu screen. • On the main menu screen, rotate the knob to select a menu item or adjust the parameter value. Press the knob to confirm the operation. • Hold down the knob and BACK button simultaneously for 5s or longer to lock or unlock the buttons.
BACK	Go back to the previous menu or cancel the current operation.

Rear Panel



Inputs		
Type	Qty	Description

HDMI 2.0-1 IN	1	Resolutions	Max resolution: 4096x2160@60Hz/8192x1080@60Hz (Forced) Min resolution: 800x600@60Hz
		Max width/height (Forced)	Max width: 8192 pixels (8192x1080@60Hz) Max height: 8192 pixels (1080x8192@60Hz)
		Frame rates	23.98 / 24 / 25 / 29.97 / 30 / 47.95 / 48 / 50 / 59.94 / 60 / 71.93 / 72 / 75 / 100 / 119.88 / 120 / 143.86 / 144 / 240 Hz
		HDR	Support HDR10 and comply with the SMPTE ST 2084 and SMPTE ST 2086 standards. Support HLG.
		EDID management	Support standard resolutions, up to 3840x2160@60Hz. Support custom input resolutions.
		HDCP	HDCP 2.2 compliant, backwards compatible with HDCP 1.4/HDCP 1.3.
		Interlaced signal inputs	Not supported
HDMI 2.0-2 IN	1	Resolutions	Max resolution: 4096x2160@60Hz/8192x1080@60Hz (Forced) Min resolution: 800x600@60Hz
		Max width/height (Forced)	Max width: 8192 pixels (8192x1080@60Hz) Max height: 7680 pixels (1080x7680@60Hz)
		Frame rates	23.98 / 24 / 25 / 29.97 / 30 / 47.95 / 48 / 50 / 59.94 / 60 / 71.93 / 72 / 75 / 100 / 119.88 / 120 / 143.86 / 144 / 240 Hz
		HDR	Support HDR10 and comply with the SMPTE ST 2084 and SMPTE ST 2086 standards. Support HLG.
		EDID management	Support standard resolutions, up to 3840x2160@60Hz. Support custom input resolutions.
		HDCP	HDCP 2.2 compliant, backwards compatible with HDCP 1.4/HDCP 1.3.
		Interlaced signal inputs	Not supported
HDMI 2.0-3 IN	1	Resolutions	Max resolution: 4096x2160@60Hz/8192x1080@60Hz (Forced) Min resolution: 800x600@60Hz
		Max width/height (Forced)	Max width: 8192 pixels (8192x1080@60Hz) Max height: 7680 pixels (1080x7680@60Hz)
		Frame rates	23.98 / 24 / 25 / 29.97 / 30 / 47.95 / 48 / 50 / 59.94 / 60 / 71.93 / 72 / 75 / 100 / 119.88 / 120 / 143.86 / 144 / 240 Hz
		HDR	Support HDR10 and comply with the SMPTE ST 2084 and SMPTE ST 2086 standards. Support HLG.

		EDID management	Support standard resolutions, up to 3840x2160@60Hz. Support custom input resolutions.
		HDCP	HDCP 2.2 compliant, backwards compatible with HDCP 1.4/HDCP 1.3.
		Interlaced signal inputs	Not supported
DP 1.2	1	Resolutions	Max resolution: 4096x2160@60Hz/8192x1080@60Hz (Forced) Min resolution: 800x600@60Hz
		Max width/height (Forced)	Max width: 8192 pixels (8192x1080@60Hz) Max height: 8192 pixels (1080x8192@60Hz)
		Frame rates	23.98 / 24 / 25 / 29.97 / 30 / 47.95 / 48 / 50 / 59.94 / 60 / 71.93 / 72 / 75 / 100 / 119.88 / 120 / 143.86 / 144 / 240 Hz
		HDR	HDR video is accepted with manual HDR configuration in VMP.
		EDID management	Support standard resolutions, up to 3840x2160@60Hz. Support custom input resolutions.
		HDCP	HDCP 1.3 compliant
		Interlaced signal inputs	Not supported
12G-SDI IN	1	Standards	Support ST-2082 (12G), ST-2081 (6G), ST-424 (3G) and ST-292 (HD) standard video inputs. Support 3G-Level A/Level B (DS mode).
		Resolutions	Max resolution: 4096x2160@60Hz Min resolution: 720x480i@59.94Hz
		Frame rates	23.98/24/25/29.97/30/47.95/48/50/59.94/60 Hz
		HDR	HDR video is accepted with manual HDR configuration in VMP.
		Interlaced signal inputs	Support interlaced signal inputs, including 1080i/576i/480i.
		Cables	Recommend using the CANARE-12G SDI coaxial cable. Cables up to 50 meters are supported.
Outputs			
Type	Qty	Description	
1–20	20	Gigabit Ethernet output ports. Support hot backup between Ethernet ports. <ul style="list-style-type: none"> • Max device load capacity: 9 million pixels • The maximum load capacity per Ethernet port is as follows. For details, see the Ethernet Port Load Capacity section. <ul style="list-style-type: none"> – 8bit@60Hz: 659,722 pixels – 10bit@60Hz: 494,791 pixels (available only with the A10s Pro receiving card) – 10bit/12bit@60Hz: 329,861 pixels 	

OPT 1–4	4	<p>10G optical output ports</p> <p>Supports setting of output mode. Users may choose between 20-port mode and 40-port mode.</p> <ul style="list-style-type: none"> • 20-port mode: <ul style="list-style-type: none"> – OPT 1 transmits the data of Ethernet ports 1 to 10. OPT 3 is the copy channel of OPT 1. – OPT 2 transmits the data of Ethernet ports 11 to 20. OPT 4 is the copy channel of OPT 2. – You can use the optical port alongside the physical Ethernet port, with priority given in the following order: OPT 1/2 > OPT 3/4 > Ethernet ports 1–20. • 40-port mode: <ul style="list-style-type: none"> – OPT 1 transmits the data of Ethernet ports 1 to 10. – OPT 2 transmits the data of Ethernet ports 11 to 20. – OPT 3 transmits the data of Ethernet ports 21 to 30. – OPT 4 transmits the data of Ethernet ports 31 to 40. – You can use the optical port alongside the physical Ethernet port, with priority given in the following order: OPT 1/2 > Ethernet ports 1–20. <p> Note:</p> <p>While in the 40-port mode, additional Ethernet ports can be used to create easier screen topology without reducing the device's maximum load capacity.</p>
HDMI 2.0-1 LOOP	1	HDMI loop through. Up to 8 devices can be cabled in one loop.
HDMI 2.0-2 LOOP	1	
HDMI 2.0-3 LOOP	1	
12G-SDI LOOP	1	SDI loop through. Up to 8 devices can be cabled in one loop.
SPDIF OUT	1	A digital audio output (Reserved)
Controls		
Type	Qty	Description
ETHERNET	2	<p>Gigabit Ethernet control ports. Support TCP/IP protocol and star topology.</p> <p>They have the same functions without priority and order, and can be connected to VMP software. No switch or router is needed to deploy multiple devices on the same LAN via device cascading as the network switching function is already built in. Up to 20 MX40 Pro devices can be cascaded.</p>
GENLOCK	1	<p>A pair of Genlock signal connectors. Support Bi-Level, Tri-Level, and Blackburst.</p> <ul style="list-style-type: none"> • IN: Accept the sync signal. • LOOP: Loop the sync signal. <p>The Genlock input signal supports a frame rate range from 23.98 Hz to 60 Hz. For standard Genlock signal generators, up to 20 MX40 Pro devices can be cascaded.</p>
AUX	1	An auxiliary port that connects to the central control device (RS232) (Reserved)
Power		
100-240V~, 50/60Hz, 1.5A	1	An AC power input connector and switch

Note

The maximum input resolution and maximum width and height of HDMI and DP connectors must be obtained by setting the graphics card.

Dimensions

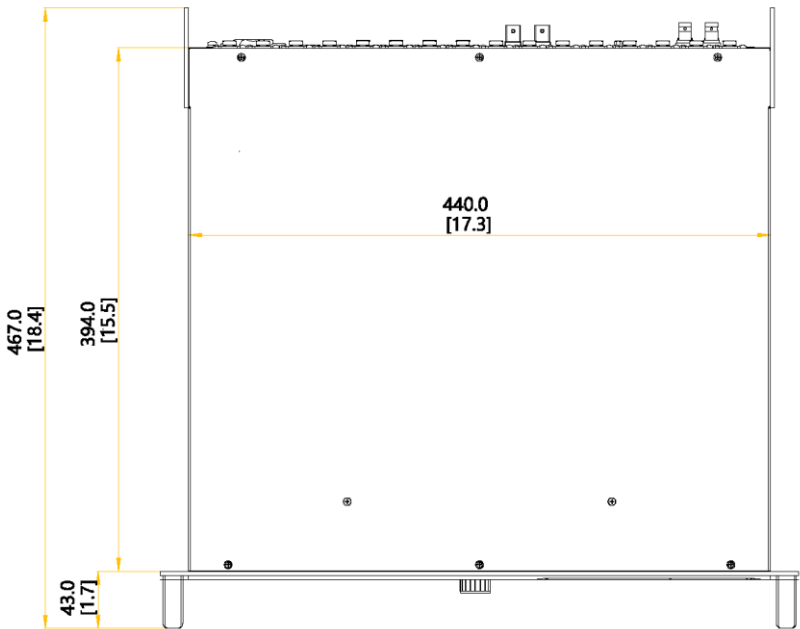
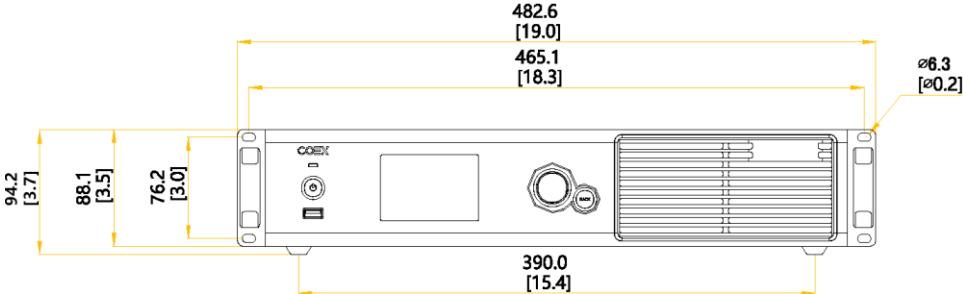

Tolerance: ±0.3 [±0.012] Unit: mm [inch]

Product Specifications

Electrical Specifications	Power input	100-240V~, 50/60Hz, 1.5A
	Max power consumption	95 W
Operating Environment	Temperature	-20°C to +50°C
	Humidity	0% RH to 80% RH, non-condensing
Storage Environment	Temperature	-30°C to +80°C
	Humidity	0% RH to 95% RH, non-condensing
Physical Specifications	Dimensions	482.6 mm × 94.2 mm × 467.0 mm

	Net weight	7.5 kg
	Gross weight	10.5 kg Note: It is the total weight of the product, accessories, and packing materials packed according to the packing specifications.
Packing Information	Packing box	660.0 mm × 570.0 mm × 210.0 mm, kraft paper box
	Accessory box	408.0 mm × 290.0 mm × 50.0 mm, white cardboard box
	Accessories	<ul style="list-style-type: none"> • 1x Power cord • 1x Ethernet cable • 1x HDMI cable • 1x DP cable • 1x Certificate of Approval
IP Rating	IP20 (Please prevent the product from water intrusion and do not wet or wash the product).	

The amount of power consumption may vary depending on various factors such as product settings, usage, and environment.

Video Source Specifications

Input	Resolution		Color Space	Sampling	Bit Depth	Integer Frame Rate (Hz)
HDMI 2.0-1	4K	4096×2160 (Forced)	RGB / YCbCr	4:4:4	12bit	24/25/30
					10bit	24/25/30/48/50
			8bit	24/25/30/48/50/60		
			YCbCr		4:2:2	8/10/12bit
		3840×2160	RGB / YCbCr	4:4:4	12bit	24/25/30
					10bit	24/25/30/48/50
			8bit	24/25/30/48/50/60		
			YCbCr		4:2:2	8/10/12bit
	2K1K	2560×1440	RGB / YCbCr	4:4:4	12bit	24/25/30/48/50/60/75
					10bit	24/25/30/48/50/60/75/100
			8bit	24/25/30/48/50/60/75/100/120		
			YCbCr		4:2:2	8/10/12bit
		1920×1080	RGB / YCbCr	4:4:4	12bit	24/25/30/48/50/60/72/75/100/120/144
					10bit	
			8bit	24/25/30/48/50/60/72/75/100/120/144/240		
			YCbCr		4:2:2	8/10/12bit

Input	Resolution		Color Space	Sampling	Bit Depth	Integer Frame Rate (Hz)	
HDMI 2.0-2 / HDMI 2.0-3	4K	4096x2160 (Forced)	RGB / YCbCr	4:4:4	10bit	24/25/30/48/50	
					8bit	24/25/30/48/50/60	
			YCbCr	4:2:2	8/10/12bit		
		3840x2160	RGB / YCbCr	4:4:4	10bit	24/25/30/48/50	
					8bit	24/25/30/48/50/60	
			YCbCr	4:2:2	8/10/12bit		
	2K1K	2560x1440	RGB / YCbCr	4:4:4	10bit	24/25/30/48/50/60/75/100	
					8bit	24/25/30/48/50/60/75/100/120	
			YCbCr	4:2:2	8/10/12bit		
		1920x1080	RGB / YCbCr	4:4:4	10bit	24/25/30/48/50/60/72/75/100/120/144	
					8bit	24/25/30/48/50/60/72/75/100/120/144/240	
			YCbCr	4:2:2	8/10/12bit	(240 Hz needs to be forced)	
DP 1.2	4K	4096x2160 (Forced)	RGB / YCbCr	4:4:4	12bit	24/25/30/48/50	
					10bit	24/25/30/48/50/60	
					8bit		
			YCbCr	4:2:2	8/10/12bit		
			3840x2160	RGB / YCbCr	4:4:4	12bit	24/25/30/48/50
						10bit	24/25/30/48/50/60
		8bit		24/25/30/48/50/60/75			
		YCbCr	4:2:2	8/10/12bit	(75 Hz needs to be forced)		
		2K1K	2560x1440	RGB / YCbCr	4:4:4	12bit	24/25/30/48/50/60/75/100
	10bit					24/25/30/48/50/60/75/100/120	
	8bit					24/25/30/48/50/60/75/100/120/144	
	YCbCr			4:2:2	8/10/12bit	(144 Hz needs to be forced)	
	1920x1080			RGB / YCbCr	4:4:4	12bit	24/25/30/48/50/60/75/100/120/144
						10bit	(144 Hz needs to be forced)
			8bit	24/25/30/48/50/60/75/100/120/144/240 (240 Hz needs to be forced)			
	YCbCr		4:2:2	8/10/12bit			
	12G-SDI		4K	4096x2160	YCbCr	4:2:2	10bit

Input	Resolution		Color Space	Sampling	Bit Depth	Integer Frame Rate (Hz)
		3840×2160				
	2K1K	2048×1080				
		1920×1080				

Note

The table above only displays a selection of common resolutions and integer frame rates. Decimal frame rates are also supported, allowing for automatic frame rate adaptation from the highest frame rate of each resolution down to 23.98/29.97/47.95/59.94/71.93/119.88/143.86 Hz.

Ethernet Port Load Capacity

When Working with A10s Pro Receiving Card

The formula of calculating the load capacity per Ethernet port and the detailed parameters are as follows.

- 8bit: Load capacity × 24 × Frame rate < 1000 × 1000 × 1000 × 0.95
- 10bit: Load capacity × 32 × Frame rate < 1000 × 1000 × 1000 × 0.95
- 12bit: Load capacity × 48 × Frame rate < 1000 × 1000 × 1000 × 0.95

Max Load Capacity per Ethernet Port (Pixels)			
Frame Rate / Bit Depth	8bit	10bit	12bit
24 Hz	1,649,305.556	1,236,979	824,653
25 Hz	1,583,333	1,187,500	791,667
30 Hz	1,319,444	989,583	659,722
50 Hz	791,667	593,750	395,833
60 Hz	659,722	494,792	329,861
120 Hz	329,861	247,396	164,931
144 Hz	274,884	206,163	137,442
240 Hz	164,931	123,698	82,465

When Working with Other Armor Series Receiving Cards

The formula of calculating the load capacity per Ethernet port and the detailed parameters are as follows.

- 8bit: Load capacity × 24 × Frame rate < 1000 × 1000 × 1000 × 0.95
- 10bit: Load capacity × 48 × Frame rate < 1000 × 1000 × 1000 × 0.95
- 12bit: Load capacity × 48 × Frame rate < 1000 × 1000 × 1000 × 0.95

Max Load Capacity per Ethernet Port (Pixels)			
Frame Rate / Bit Depth	8bit	10bit	12bit
24 Hz	1,649,305.556	824,653	824,653
25 Hz	1,583,333	791,667	791,667
30 Hz	1,319,444	659,722	659,722
50 Hz	791,667	395,833	395,833
60 Hz	659,722	329,861	329,861
120 Hz	329,861	164,931	164,931
144 Hz	274,884	137,442	137,442
240 Hz	164,931	82,465	82,465

Note

The maximum load capacity is only achieved when the load width of a single port is 128 pixels or more. If the load width is less than that, the load capacity will be reduced accordingly, calculated as $(128 - \text{load width}) \times \text{load height}$.

Notes and Cautions

Notes for Battery

- The battery is not intended to be replaced.
- Disposal of a battery into fire or a hot oven, or mechanically crushing or cutting of a battery can result in an explosion.
- Leaving a battery in an extremely high temperature surrounding environment can result in an explosion or the leakage of flammable liquid or gas.
- A battery subjected to extremely low air pressure may result in an explosion or the leakage of flammable liquid or gas.

Notes for Installation

When the product needs to be installed on the rack, 4 screws at least M5*12 should be used to fix it. The rack for installation shall bear at least 32kg weight.

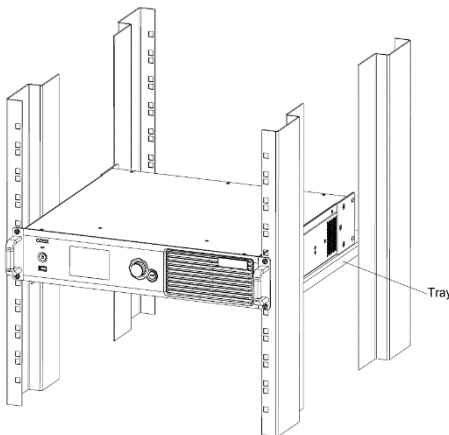

- Elevated Operating Ambient - If installed in a closed or multi-unit rack assembly, the operating ambient temperature of the rack environment may be greater than room ambient. Therefore, consideration should be given to installing the equipment in an environment compatible with the maximum ambient temperature (T_{ma})

specified by the manufacturer.

- **Reduced Air Flow** – Installation of the equipment in a rack should be such that the amount of air flow required for safe operation of the equipment is not compromised.
- **Mechanical Loading** – Mounting of the equipment in the rack should be such that a hazardous condition is not achieved due to uneven mechanical loading.
- **Circuit Overloading** – Consideration should be given to the connection of the equipment to the supply circuit and the effect that overloading of the circuits might have on overcurrent protection and supply wiring. Appropriate consideration of equipment nameplate ratings should be used when addressing this concern.
- **Reliable Earthing** – Reliable earthing of rack-mounted equipment should be maintained. Particular attention should be given to supply connections other than direct connections to the branch circuit (e.g. use of power strips).

FCC Caution

Any changes or modifications not expressly approved by the party responsible for compliance could void the user's authority to operate the equipment.

This device complies with part 15 of the FCC Rules. Operation is subject to the following two conditions: (1) This device may not cause harmful interference, and (2) this device must accept any interference received, including interference that may cause undesired operation.

Note: This equipment has been tested and found to comply with the limits for a Class A digital device, pursuant to part 15 of the FCC Rules. These limits are designed to provide reasonable protection against harmful interference when the equipment is operated in a commercial environment. This equipment generates, uses, and can radiate radio frequency energy and, if not installed and used in accordance with the instruction manual, may cause harmful interference to radio communications. Operation of this equipment in a residential area is likely to cause harmful interference in which case the user will be required to correct the interference at his own expense.

Others

This product can only be placed horizontally. Do not mount vertically or upside-down.

This is Class A product. In a domestic environment, this product may cause radio interference in which case the user may be required to take adequate measures.

TECNOGROUP
LED TECHNOLOGY EXPERTS

Tel: +56 9 5449 1032
Email: contacto@tecnogroup.cl

Casa Matriz
Padre Hurtado Central 580
Las Condes, Santiago de Chile

www.tecnogroup.cl

 @tecnogroup.cl  #tecnogroup.cl  Tecnogroup Chile

Tel: 833 533 4255
Email: info@tecnogroup.us

Showroom Miami
759 NW. 24th ST.
Miami, FL 33127

www.tecnogroup.us

 @tecnogroup.us  #tecnogroup.us  Tecnogroup USA